

Annex 1a - Core Specification

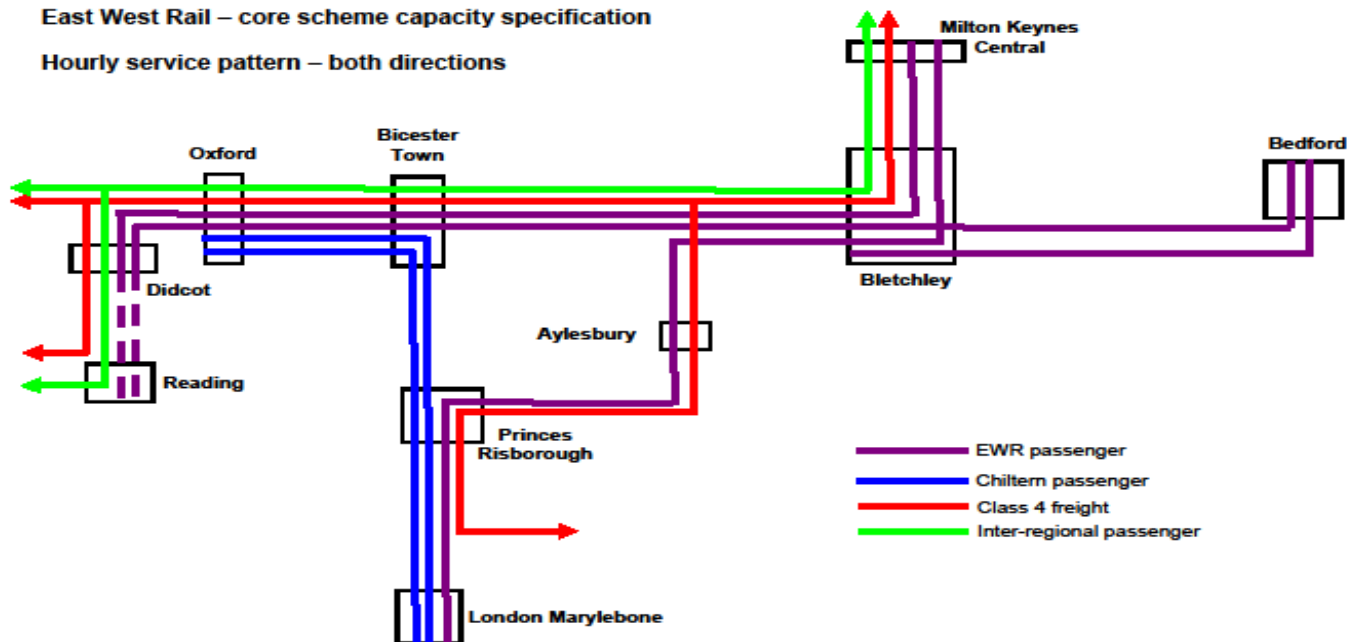

Annex 1b - Enhanced Specification

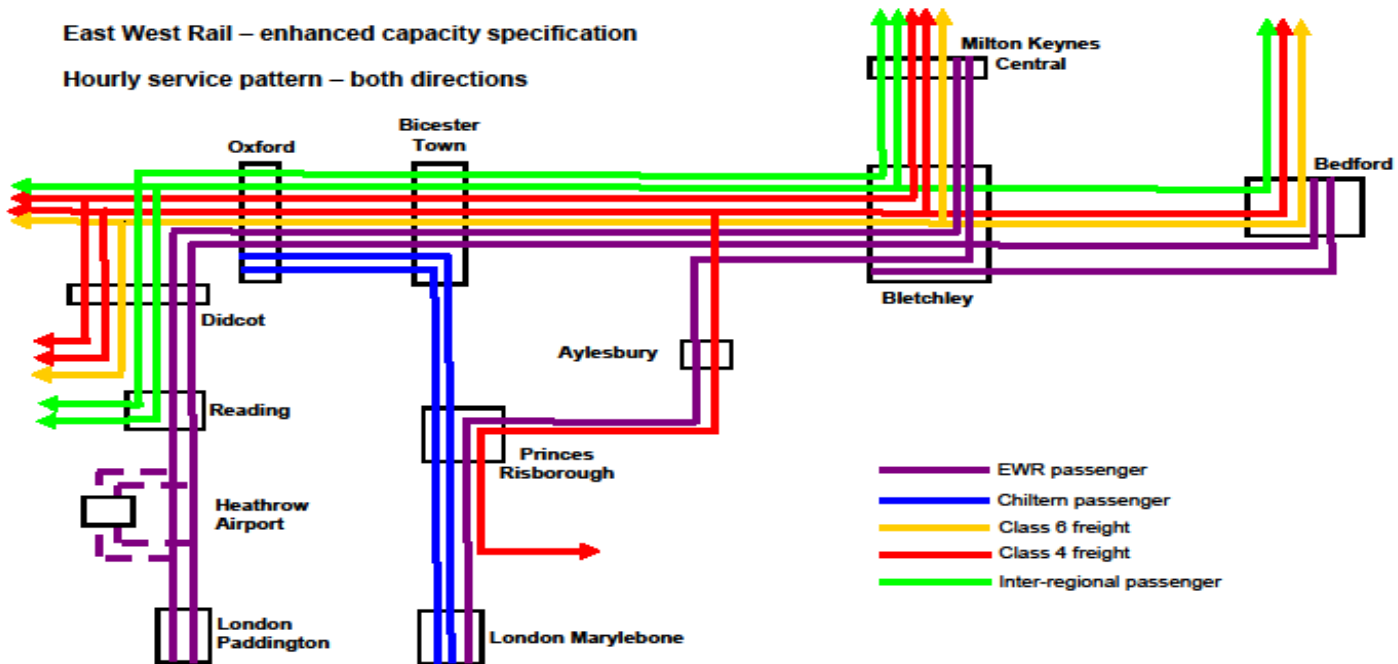

Annex 2 - Population and growth



Top 14 Cities by Population Size

- 1 Wolverhampton
- 2 Leicester
- 3 Portsmouth & Southampton
- 4 Reading
- 5 Bournemouth
- 6 Middlesbrough
- 7 Stoke
- 8 Coventry
- 9 Hull
- 10 Sunderland
- 11 Brighton
- 12 Preston
- 13 Southend
- 14 Plymouth

Top 6 Cities by Population Growth

- 1 Milton Keynes
- 2 Swindon
- 3 Oxford
- 4 Norwich
- 5 Cambridge
- 6 Ipswich